

# Model 2940-006/2940-016, 102°, 12.3 dBi(10.2 dBd)Panel

## ELECTRICAL CHARACTERISTICS

<b>Frequency Range</b>	806 - 960 MHz
<b>Beamwidth: Horizontal-plane</b>	102° ± 2° (at -3 dB)
<b>Vertical-plane</b>	19° ± 2° (at -3 dB)
<b>Maximum / Minimum Gain</b>	12.3/11.7 dBi (10.2/9.6 dBd)
<b>Electrical Downtilt</b>	0° (available -6°, -10°, -15°)
<b>Side Lobes</b>	≤ -11 dB
<b>Front-to-Back Ratio</b>	≤ -19 dB

## GENERAL CHARACTERISTICS

<b>Impedance</b>	50 Ω
<b>VSWR</b>	≤ 1.5:1
<b>Polarization</b>	Vertical
<b>Rated Power</b>	500 W

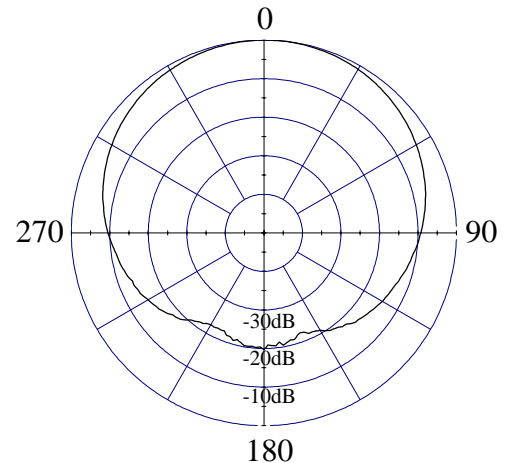

**HORIZONTAL - PLANE**

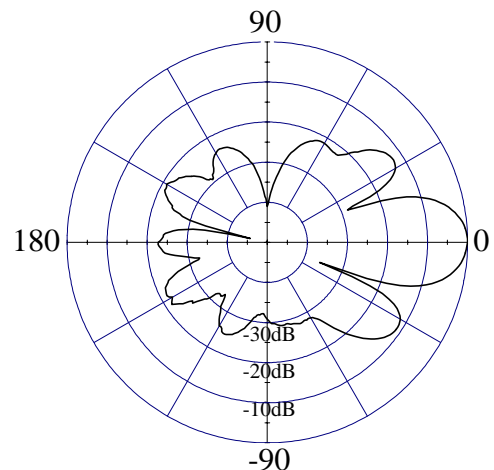

**VERTICAL - PLANE**





# Model 2940-006/2940-016, 102°, 12.3 dBi(10.2 dBd)Panel

## MECHANICAL CHARACTERISTICS

<b>Height x Width x Depth</b>	37" x 9.3" x 7" (940 x 235 x 180 mm)
<b>Weight</b>	13 lbs (5.9 kg)
<b>Wind Survival Rating</b>	125 mph (200 km/h)
<b>Wind Load (at 100 mph)</b>	351 N (frontal F1) 248 N (lateral F2)
<b>Flat Plate Equivalent Area</b>	2.38 ft <sup>2</sup> (0.22 m <sup>2</sup> )
<b>Connector Types (Female)</b>	Type N, or 7/16 DIN
<b>Materials: Antenna / Radome</b>	Aluminum / ABS

SIDE VIEW

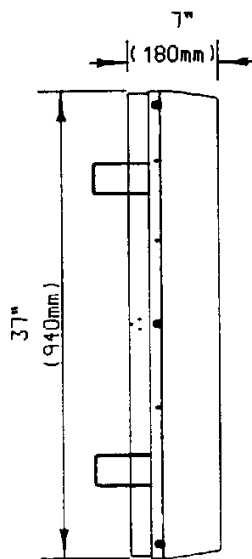

REAR VIEW

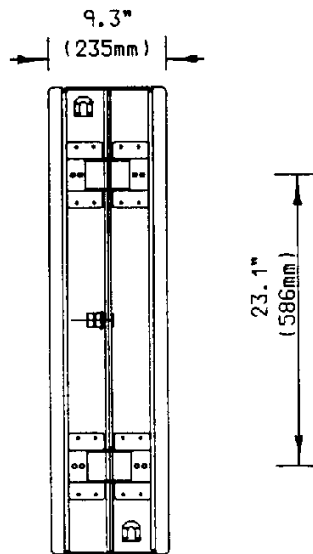

TOP VIEW

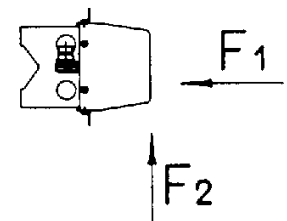

## MOUNTING HARDWARE

<b>Mounting Brackets (standard)</b>	<b>Fix 903</b> (1.25" - 3.5" OD pipe) (30 - 90 mm OD pipe)
<b>Mounting Brackets (optional)</b>	<b>Fix 905</b> (2" - 4.7" OD pipe) (50 - 120 mm OD pipe)
	<b>Fix 902</b> (4.5" - 6.6" OD pipe) (115 - 170 mm OD pipe)
<b>Mechanical Tilt Brackets (optional)</b>	Model <b>307780</b>